

Instructions for Guests at 110 Momenee Lane - Eagles View House

Emergency Phone Numbers

- Jay / Marci 603 226-2282
- Chummy & Lynn Lassonde (Friends in Pittsburg, they built the house and are also the caretakers) 603 538-6503

Things to Bring

- In the winter, do not bring a car. You really need a four wheel drive vehicle.
- Sleeping bags unless you want to wash the linens when you leave.
- Swim suits - there is a 5-person hot tub
- Food. There is only one grocery store and it's pretty good but you never know if they will have what you need. There is a complete set of spices, oils, and things like that at the house. There is also an outside gas grill.
- Good quality contractor trash bags. You can't leave trash at the house and you don't want to be driving home with your trash in cheapo trash bags.
- An extra DVD player and/or video games – there is only one DVD player and 2 TVs. Both TV's are HD, fairly new and very large (52" or more).

Things to Leave Home

- 2-Wheel drive vehicles (in the winter)

Beds

- 1 King Size in Master
- 1 Twin in Master
- 2 Twins in Guest Room 1
- 2 Twins in Guest Room 2
- 1 Long couch in Living Room
- 1 Long couch in Loft
- 1 Chaise in Loft
- 1 Long couch in cellar game room

Arriving

- Turn breaker on in cellar for the well pump
- Note the location of the fire extinguishers

- First Floor - Next to fridge
 - Second Floor – Outside Master BR door
 - Cellar – next to door leading to the garage
- If you are considering changing the hot tub water, do it now. (See instructions below). Otherwise, turn the hot tub up to 103 degrees. It should be at 90 in summer, 95 in winter when no one has been using the house. It will take a few hours to reach 103.

Hot Tub

- Throw 2 teaspoons of MPS Oxidizer in and push the “clean button” 30 minutes before use but not more than once per day. Chemicals are in the hallway closet by the door to tub (where the games are) and the measuring spoons are on the back of the closet door.
- The hot tub cover is on a hinge. To open it, unlatch the 2 straps on the control panel side and slide the cover back 6-8” before you try to tip it back on its hinge.
- Be absolutely sure that the hot tub cover is locked down (clicks) when you are done or the wind may blow it open. You only need to lock the 2 straps on the side of the tub that the control panel is on.
- When your stay is over, add 1 tablespoon of chlorine and press clean. If you add chemicals, please note it in the log on the back of the closet door so the caretaker knows.
- If the control panel appears to be locked (it will say “SPA” and have a padlock icon) press the “-“ temp key and the “-“ light key simultaneously to unlock.
- To get the light to oscillate different colors, press the “+” light key until the color is red. Then press the “+” key one more time and leave it alone for 10 seconds... lights will start to change color.
- Be sure any kids use the bathroom before they go in. If someone urinates in the tub (and you’ll know it if they do), the entire spa has to be drained and refilled – chemicals can’t fix that.
- There are hooks for wet bathing suits in the downstairs bath tub / shower unit.
- If you have to / want to drain and refill the tub, here is the procedure:
 - Press the black button on the GFCI breaker box at the end of the power cord where it plugs into the house. This is the most important step. If you do not do this, the heater high-limit switch will trip off due to a lack of water and you will have to reset it (more on this below).
 - Now that the power is off, verify that it is off by noting that the control panel is completely off / dark.
 - Get the hose from the cellar that does not have a quick disconnect fitting attached to it (There are two hoses). Attach it to the hot tub at its base (just off the ground and below the

control panel). There is no need to remove the tub access panel(s). The place where the hose attaches is hard to see and you will have to get down on your hands and knees – it's just off the floor.

- Remove the hose cap and attach the hose. Run it down the hill a bit to get the water away from the house.
- To start the water flowing, turn the miniature petcock (just behind where the hose attaches) so that it is in-line with the hose.
 - **IMPORTANT:** If you suspect the petcock is frozen, use a hair dryer or the portable heater from the cellar to unfreeze it. This should not happen unless the last person to fill the tub left the petcock on. Please do not make the same mistake they did.
- As the tub drains, keep an eye on the water level. If it's below freezing outside, you must start filling the tub as soon as it's done draining or you risk freezing (damaging) some components in the tub.
- When the tub is almost empty, run the other hose (that has the quick disconnect) from the laundry room to the tub. Routing it out the bedroom window works well.
- Connect the quick disconnect to the water valve above the washing machine by sliding the female receptacle straight back and inserting the male end.
- Turn on the water by turning the mini petcock on the "Y" connector above the washing machine.
- Rinse the tub a bit (you should still be draining it at this point). If you can, try to wash and wipe down any scum, etc using Windex or other mild non-sudsing cleaner – just be sure to rinse it well and let that water drain all the way out.
- With all the dirty and/or soapy water clear, turn off the drain line petcock, remove the drain hose and place the hose cap back on the drain. **DON'T JUST PUT THE CAP BACK ON, YOU MUST TURN OFF THE PETCOCK AS WELL!!!!**
- Fill the tub back up. The fill line is about 2" above the highest chrome trim ring of the jets.
- Turn off the petcock on the "Y" above the washing machine.
- Before rolling the hose up, disconnect the quick disconnect and lift the hose high over your head. Move down the length of the hose lifting each section over your head to get all the water out so you don't make a mess on the floor.
- Roll up hoses, put them in the cellar.
- Restore power to the tub by pressing the yellow button on the GFCI box at the end of the power cord where it attaches to the house.

- Continue to check the tub temperature to be sure the heater is working. If the water gets colder, you may have tripped the heater's high limit breaker. To reset it, press the black button on the GFCI breaker box and leave it powered off for 20 minutes. Then press the yellow button to restore power.

Fireplace

- Turn the damper to the right (clockwise) to open.
- Before lighting, open a window on the first floor living room quite a bit (6" or so). The house is too tight for the flue to draw without a window open. Once the fire is going well, you can close it most of the way but still leave it open about 2"
- Build the fire toward the back of the fireplace and start the flue drawing air by holding a lit crumpled newspaper up high inside the chimney. If you don't you will probably fill the house with smoke. If that happens, open the top half of the windows (pull the tops down) in the loft and turn on the fan in the loft (it should be in the direction to pull the smoke up).
- Be absolutely sure that any fire is completely out before you leave and then close the damper. If you have to, use water to help put out any coals. If you think that there may still be some coals smoldering, leave the damper open a crack. The caretaker checks the damper every few days so it's not a big deal if you have to leave it open a bit.
- Clean out the fireplace using the ash can and throw the ashes in the driveway (not in the woods in case they are still hot.)

Sheets and Towels

- Please wash and dry all sheets and towels before you leave and place the sheets folded on the end of the beds they go to.
- Please don't fit the sheets back on the beds because it is unclear which one's are clean and which are dirty.

TV and Stereo

- The dish network remote can be used for the TV and satellite.
- The LG remote is for the stereo (and you can pipe the TV though it too).
- To watch a DVD you have to press "source" on the Samsung (TV) remote until you it working.
- Use the LG remote for the volume, and also to select the source you want to hear. Pressing "input" cycles through the different sources. To hear the TV sound through the stereo, select "Optical 1"

- You can listen to an iPod or other device that has Bluetooth through the LG sound bar. On the front of the sound bar, press the “F” button until “BT” comes up on the display. Then on your iPod/Mp3 player, turn on your Bluetooth function and select “LG Audio”. Voila, should work great but you probably need to stay within 20 feet of the sound bar or it will stop working.

Internet / Phone Connection

- There is a wireless internet connection in the house. The settings are listed below. It uses a DSL connection.
- The network name is “alosa” and the encryption key is 6036035386424 (it’s the phone number with area code entered twice)
- Phone number is (603) 538-6424
- There is cell reception at The Buck Rub Pub, Tall Timbers, the Trading Post and Dubie’s.

Door Locks / Keys

- The sliding door can be hard to lock and unlock. You have to pull it toward the jamb while locking. Pull on it to make sure it’s locked.
- Don’t bother to lock any door when leaving for a few hours.
- The best way to get in and out is if you have a garage door opener. If you don’t have a garage door opener, you have to go in the front door (facing the lake).

Outside Thermometer

- Thermostat opposite the cellar stairs has a button to see the outside temp and weather forecast.

Trash

- There is no garbage pickup so you must take all your trash with you when you leave. Be sure to check all the trash cans including the cellar and bathrooms.
- Take any perishables home with you that won’t last more than a couple weeks.

Alarm

- Currently the alarm is not working

Local Businesses

- For groceries, there is Young's store which is only a mile or two up (north on) Route 3.
- There are two hardware stores just before Young's.
- The nicest restaurant is the "Rainbow Grille" at Tall Timbers, which is across the lake to the west. Their phone number is 538-9556. Call 2 days ahead for dinner reservations if you can. The bar opens at 5:00; get there early for a seat. During snowmobile season, they open at 3:00 with a limited pub menu.
- Tracy's Hillside Grille and the Buck Rub Pub are right near the house on Route 3. They are also both accessible from the snowmobile trails.
- On the road to the Rainbow Grille at Tall Timbers is the Back Lake Tavern. Nice people and rarely crowded.

Wood Furnace

- The wood furnace is just for emergencies. Please do not use it unless you need to (like if you run out of oil or power which should never happen).
- Just in case you need to use it:

There are 2 switches on the wood furnace. Both must be on for the furnace to work properly. In the event there is no power for an extended period of time, the wood furnace should still circulate hot water on the first floor via a gravity loop.

Below is a drawing of how the two furnaces work together – something most people will never need to know.

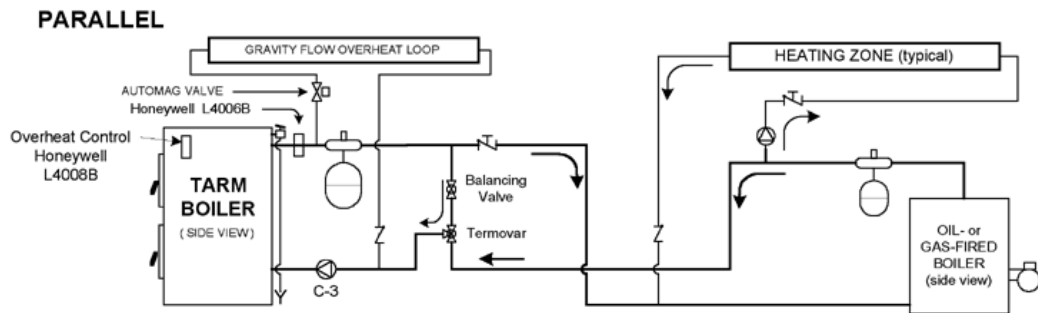

Games

- Games and musical instruments are in the front hall closet.

Games	Sports Stuff	Musical Stuff
Cribbage	Frisbee	Guitars (2)
Poker Chips	Football	Bongos

Pictionary	Air Rifle (Pellet gun)	Tambourine
Jenga		
Scrabble		
Trivial Pursuit		
Cranium		
Skip-Bo		
Uno		

Tools

- There is a full set of tools in the cellar.
- There is a battery charger and battery boost kit in the cellar and/or garage.
- There is a tow rope and chains in the garage or in the bag on one of the snowmobile.

Owners's Manuals

- Owners's manuals for most of the major appliances, etc. are in a flexible file folder in the bottom section of the antique ice chest in the pantry.

OHRVs

- Please do not use the snowmobiles or ATV's. If you use the gas cans, be sure to add gasoline stabilizer to any gas left in the cans.
- There are trail maps in the white hutch.
- You can generally ride directly down the front hill of the house. There is a very wide trail there (big enough to drive a car on in the summer). You can also access trails via Momenee Lane.

First Aid

- Bandages, antiseptics, antacids and the like are in the first floor bathroom closet. Please replace anything you use.

Checklist for Leaving

This stuff is REALLY IMPORTANT!!! PLEASE DO ALL OF THIS!!!

- Blow out candles.
- Make sure the microwave fan and light are off.
- Clean the coffee maker.
- Turn the hot tub temp down to 90 degrees in the spring and summer, 95 in the winter.
- Hot tub cover locked down.
- Lock all windows.
- Clean out chimney ashes unless they're smoldering. You can throw the ashes outside in the driveway. Be careful they are far enough away from the woods that they cannot catch fire.
- Close damper on chimney (leave open a crack if you're concerned about smoldering coals)
- Three Thermostats to 62 – 1 in master bedroom, 1 opposite cellar stairs, 1 in cellar game room
- Empty all small trash cans in cellar, bathrooms, bedrooms, etc.
- Take all trash home with you.
- Take all food home with you – especially perishables.
- Open all interior doors (except for cellar door) to allow heat to circulate in the house.
- Open cabinet doors under the kitchen sink to allow heat to enter the cabinet.
- Make sure garage doors (overhead doors) are closed.
- If you used the last of something, please make a note on the whiteboard (paper towels, toilet paper, soap, etc).
- **Turn breaker for well off.**
- Make sure you turned the breaker for the well off ☺.

Directions

- Take **93 NORTH** through Franconia Notch to **EXIT 35** which is **ROUTE 3 NORTH**.
- Follow **ROUTE 3 NORTH** all the way to Pittsburg (about 2 hours on Route 3)
- Be sure when going through all the small towns to obey the speed limits. They're really strict about this.
- Once in Pittsburg, **ROUTE 3** travels along a very large lake. This is Lake Francis.
- When **ROUTE 3** starts to veer away from the lake, you are getting close.
- Look for "**Spruce Cone Cabins**". When you see this, you are almost there.
- **TAKE A LEFT** on **SPOONER ROAD** it is opposite a sign on the right for Hidden Acres Campground.
- Follow **SPOONER ROAD** along Back Lake for approx 3/4 mile and **TAKE A LEFT** on **BEAR HILL ROAD**.
- Proceed up the hill for a few hundred feet and take a left on **MOOSE MUCK ROAD**.
- Follow **MOOSE MUCK ROAD** for a couple hundred feet and **TAKE A LEFT** on **MOMENEE LANE**
- We are about 100 yards the on the left. It is log-sided home with a small green sign on the house that says "Eagle's View".

